

Structural Glass Observation Boxes (Willis Tower Ledge)

Terry R. McDonnell, David Thompson

*Halcrow Yolles, Chicago, USA, Terry.McDonnell@halcrowyolles.com,
David.Thompson@halcrowyolles.com*

The 1,350 foot high Willis Tower (formerly known as Sears Tower) was looking for a grand attraction for their Skydeck in 2008. Few structures in the world have glass floors (both interior and exterior), and almost all are continuously supported along their edges with steel supports. In order to create a dramatic, unimpeded view of the City of Chicago the Skydeck Owners conceived of a glass platform that would protrude out of the building envelope and enable tourists, guests, and long time residents of the City to walk outside the building and look down the 1,350 foot exterior to the sidewalk below and have un-impeded views of the city. The structural glass floor system was designed to be supported by glass wall panels on three sides. In addition, the entire platform was constructed to be movable; into and out of the building. By allowing the glass observation box to move it could be constructed on the interior of the building and enable the automated window washing system for the rest of the building to continue functioning un-obstructed as well. Every piece of glass on this structure is designed to carry pedestrian loads and work with elegant connections that are at once exposed and architecturally sculpted to disappear when the view of the city is observed by the guests on top of the highest structural glass floor in the world. In addition to gravity loads, and coordinating the retraction mechanism, the glass was designed with attention to redundant laminates and supports, according to the buildings high wind loads, and requiring special permissions by the City of Chicago for construction to begin.

Keywords: Structural Glass, Laminated, Tempered

1. Introduction

The Skydeck's website states, "*The Ledge brings an exhilarating new experience to the Skydeck. At 1,353 feet up, The Ledge's glass boxes extend out 4.3 feet from the skyscraper's Skydeck on the 103rd floor, providing never-before-seen views of the city.*" [1] The goal of designing the 'never-before-viewed', or 'not viewed' is exactly what this project is all about. First and foremost this project was about providing a new experience to Chicago natives and visitors alike by allowing them to step outside of a skyscraper, look straight down, then look back at the building's exterior in a way that only a few maintenance personnel have in the past. Secondly, to do this with an unimpeded, completely transparent view that would require new and imaginative ways to make the structure 'disappear'.



Figure 1: Completed Ledge Skybox looking West over the City of Chicago. [4]

2. Project Description

The innovative boxes, which measure 12 feet high by 10 feet wide and have floor space of approximately 4.3 feet by 10.5 feet, extends out of the west elevation of Willis Tower at the 103rd floor. The original concept was a steel frame structure that protruded from the tower with glass panels attached directly to the steel members. During the design, glass engineers were able to take that concept one step further and eliminate the perimeter steel at the sides and along the floor of the glass boxes, thereby creating a near invisible structural support system. This system makes the spectacular views possible by hanging the glass panels of the boxes from cantilevered steel frames and strategically hiding the structural supports above the ceilings, and behind interior walls adjacent to the perimeter building columns. As the tenant space below the Skydeck floor is currently occupied, it was necessary to hang all of the loads for the glass boxes and frame from the ceiling structure, as it was not cost effective to reinforce the floor structure below. The only visible hint of support appears as small stainless steel clips on the sides and floor of the structures.

3. Challenges

One can imagine (like many engineering projects), that there were many challenges that were necessary to overcome in order to complete a project of this visibility, or near invisibility if you will. This project was no exception and this paper attempts to describe some of the more notable challenges and describe their solutions in brief.

3.1. Retraction

One significant issue that compounded the project challenge and required the full attention of Halcrow Yolles engineers was the constructability limitations for the project. The Skydeck management requested that the boxes be fully retractable and be

constructed without adding additional cranes or platforms to the building exterior. The retraction was of particular importance because of potential interference with the automated window washing system for the building. The skyscraper windows are washed by an automated rig that travels along vertical tracks aligned with the exterior building columns. In order to continue using this system and not investing in re-tooling the window washing system, it was necessary to design the glass boxes to retract flush with the existing building façade.

Halcrow Yolles wrote design guidelines that required top and bottom rails that would lock roller bearings into place at pre-determined points along the tracks. A simple linear beam oscillating motor would then push and pull each box back and forth depending upon the position required by building maintenance. An added benefit to this design is that the rails could be extended far enough into the building in order to allow the entire box (steel and glass) to be assembled on the 103rd floor interior, installed on the rails, and then pushed out into its normal operating position. No major cranes or exterior work was required for the project.

The interior of the 103rd floor Skydeck was equipped with a raised floor in order to hide the bottom rails of the observation boxes. Once in place, however, this raised floor became a conflict with the box itself when retracted into the building. The solution was to place the portion of the raised floor immediately behind the observation boxes on a pneumatic lift (akin to a miniature automobile lift). During the retracting process, the floor is automatically lowered to allow the glass boxes to slide into the building seamlessly.

The boundary of the retractable box was sealed with a pneumatic vulcanized seal that would deflate when the box was in motion, and could inflate into a bearing seal on the edges of the glass boxes. In addition, a wiper seal was also installed at the top and sides to direct water away from the box perimeter.

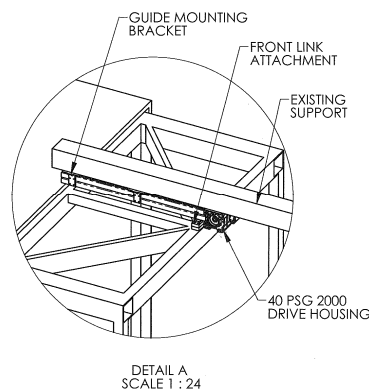

Figure 2: Schematic diagram of the retraction system proposed for the glass boxes. [2]

3.2. Wind Loads

The glass boxes were designed to withstand the most severe loading combinations prescribed by the building code. This included a rather in-depth evaluation of the wind

Challenging Glass 2

pressures that may act on the boxes. Due to the position of the boxes, they could be defined as a protruding element of a building, that in turn could be subject to increased wind pressure. Possibly larger pressures than those acting on the broad building surface at the same height. Historical wind tunnel testing has observed that wind hitting the broad flat surfaces of a building are redirected locally up, down, or around the corners of a building, and this wind may accumulate in short gusts larger than main wind load values.

The glass boxes were evaluated by a wind tunnel laboratory and by multiple building codes in order to determine the likelihood that this phenomenon would occur. In the final design the wind pressure loads were used that accounted for this behavior.

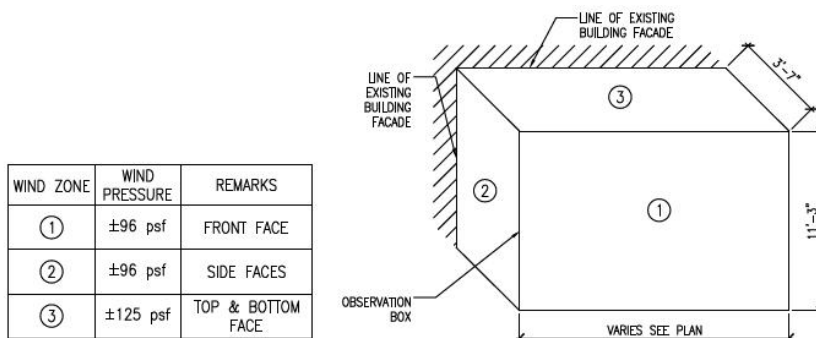

Figure 3: Design Wind Loads

3.3. Steel Supports

The support system needed to be transparent, and stiff enough to allow the retraction system to work without allowing any large deformations or stresses into the bearings or the glass panels. The design required a number of locations where load could be transferred away from both sensitive areas and into the base building. Furthermore, the tenant space below the Skydeck floor is currently occupied by telecommunication equipment. As a result, the entire gravity load had to be resisted from above, thus the entire glass box was hung from two rails hidden within the ceiling.

Structural Glass Observation Boxes (Willis Tower Ledge)

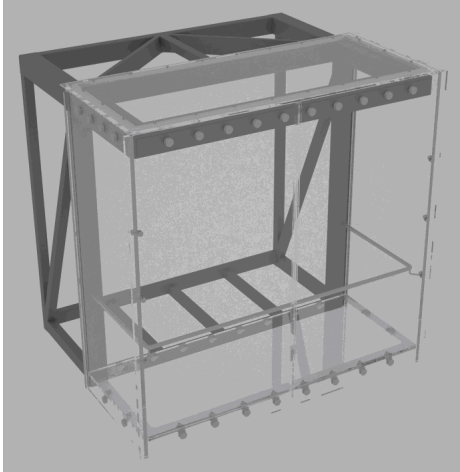

Figure 4: Glass Observation Box Steel Framing Rendering.

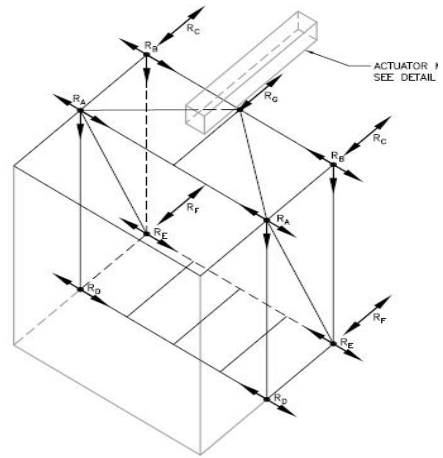

Figure 5: Glass Observation Box Framing support points.

Stiffened steel trusses comprised of structural tubes made up the ceiling, floor, and side walls of the glass box. All of this steel was positioned above the ceiling, below the floor, and behind walls to maximize the near invisible structural experience of the view. The glass eventually was only connected to a cantilever tube steel beam protruding overhead from the ceiling, which is barely noticeable when guest approaches the edge of the box and looks down.

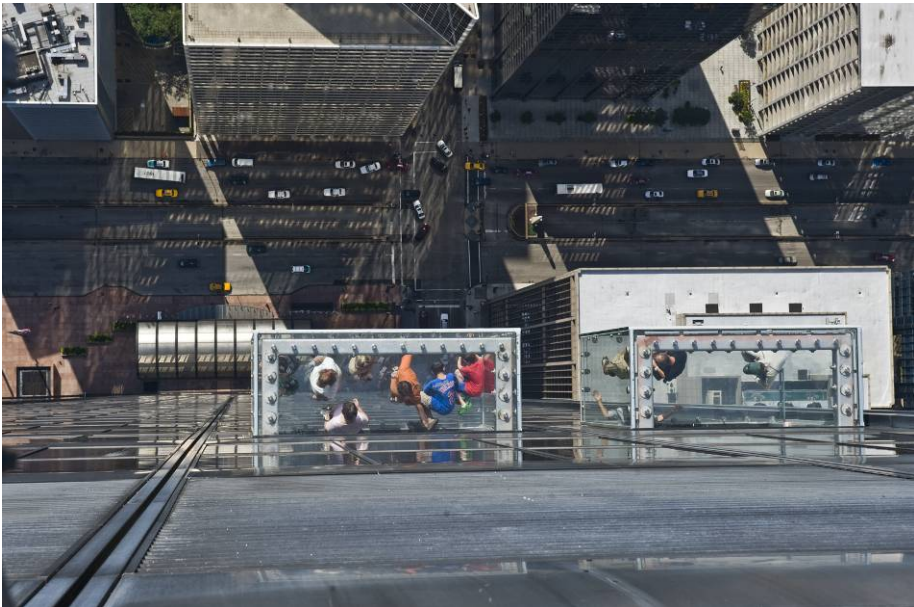

Figure 6: View of glass boxes from above [4].

3.4. Structural Glass

The main achievement of this project was utilizing the glass exterior panels and floor to resist the gravity floor loads of the Skydeck guests and the exterior wind and temperature loads simultaneously, thus enabling a nearly invisible view of the city. To accomplish this, the glass was comprised of (3) ½” thick tempered and laminated panels. The panel clarity was achieved by specifying low iron glass and using Sentry Glass Plus ultra clear laminates. The multiple laminates provided an inherent redundancy to the system in the event of wind blown debris or vandalism that limits damage to only one layer of glass. The glass was also specified to be heat soaked in order to provide high quality glazing for a public occupancy use.

The glass panels were modeled as full finite elements (including the connections and steel frames) using SAP, then RFEM to verify the results. The analysis models were performed in both pre and post-breakage conditions, to satisfy the traditional glass redundancy requirement of standard practice. Once the maximum stresses in each glass panel were determined, the engineers then reviewed five different glass design standards. Each panel’s maximum stress was then evaluated vs. all five standards.

For the purposes of this project the engineers used the following guidelines:

- Existing American ASTM 1300 & 1048
- Proposed American ASTM WK 9268
- Canadian CAN/CGSB1220
- German DIN 18008
- Austrian ONORM 3716



Figure 7: Finite Element Analysis of a glass observation box floor panel .

Structural Glass Observation Boxes (Willis Tower Ledge)

Code	Allowable Stress	
	MPa	ksi
ASTM C 1048	107.4	15.6
ASTM WK9258	85.5	12.5
CAN/CGSB1220	87.9	12.8
DIN 18008	82.5	12.0
ONORM 3716	82.5	12.0

Figure 8: Allowable stresses determined vs. five different glass design guidelines for a post-breakage condition.

3.5. Glass Connections

The structural steel, glass panels, and glass connections were customized for this project. The connections were made out of stainless steel through bolts with a pancake button on each side of the glass panels. The glass panels were manufactured with oversized bolt holes. In the field the glass panels were fitted with stainless steel through bolts and massaged into place for just the right fit in order to provide adequate tolerance around the bolts for the injected resin. Once in place the bolts allowed for resin to be injected into the remaining bolt hole cavity. The resin was injected until the contractor could ensure that the glass had continuous contact with the resin, thus a complete bearing connection was possible.



Figure 9: Typical glass connections. Heat tape strips are located inside the aluminum edge at the bottom. [3]

3.6. Incorporation of Building Services

The project challenges and uniqueness can also be attributed to the amount of cohesiveness between the glass structure, the support structure, and the necessary building systems that were installed to make the project a success. One main concern of the MEP consultant was that the glass wall panels might fog, or collect small amounts of moisture. Either occurrence might be perceived as a lesser experience by the guests of Skydeck. In order to minimize these concerns, the MEP consultant wanted to ensure hot air was blown across the inside surface of the glass wall panels. This was accomplished by perforating the cantilevered steel tube that supports the glass wall panels at the top of the box. The tube effectively became an air duct that transported warm air through perforations made within this steel tube directly onto the glass wall panels. In addition, heat trace was installed at the top and bottom edges of the glass boxes in order to limit ice building at the corners.

4. Conclusion

The Ledge at Willis Tower was initially inspired to develop a leading-edge attraction that would successfully increase visitor attendance and enhance the Tower's public appeal and significance as a Chicago landmark. Since opening in July 2009, it has doubled visitor attendance in the first three months following their opening, over the same period the previous year. This thrilling attraction is not only appealing to city tourists but also to Chicago residents. By attendance counts it appears people have been inspired by the glass Ledge to revisit the Tower after many years.

By applying general engineering principals to glass, Halcrow Yolles engineers were able to provide a load bearing glass solution that stripped away the bulky steel supports that are hallmarks of traditional engineering within the US. It is the hope of this project team, that by showing good, sound engineering using glass building material in ways that are safe and reliable, many more cutting-edge projects will be realized by owner's, architects, and developers for their next project within the US.

5. Acknowledgements

The major project contributors include, but are not limited to: David Wittenberg, David Waratuke, Elizabeth Stek, J. Kooymans, and Amy Courtright.

6. References

- [1] Skydeck Ledge Website at the Willis Tower, <http://www.theskydeck.com/theledge.asp>.
- [2] Serapid, Rigid Chain Engineers, 5400 18 Mile Road, Sterling Heights, MI 48314, document PP01-08-0521, dated 5/23/2008.
- [3] Photo courtesy of www.ChicagoPhotoShop.com
- [4] Photo courtesy of Skydeck at the Willis Tower.

Structural Glass Observation Boxes (Willis Tower Ledge)



Figure 10: The glass observation boxes as viewed from below. [4]