

# A new Façade Concept for an Existing Office Building

Iris Maniatis, Barbara Siebert

*Ingenieurbüro Dr. Siebert – Consulting Engineers, Munich, Germany,  
ima@ing-siebert.de, www.ing-siebert.de*

In this paper a case study is presented relating to the redesign of an office building dating from the 1960s. Especially the detailing and the structural complexity of designing the new double skin façade are described. The building consists of a two-storey podium topped by a nine-storey tower, the overall height is 40m above ground level. In order to optimise the building's energy efficiency and present the public a modern appearance the whole building is completely renovated. The existing building envelope which mainly consisted of prefabricated concrete elements was dismantled and is now replaced by a transparent floor to floor double skin façade. Within the renovation two new storeys (12th and 13th floor) are added.

**Keywords:** redesign, double skin facade, structural detailing

## 1. Introduction

Rising energy costs and amendments to regulations have strengthened the society's awareness of energy saving measures. In order to reduce CO<sub>2</sub> emissions many buildings dating from the 1960s and 1970s are being now refurbished. They scarcely comply with the stricter building standards introduced in recent years and very often need to be renovated not only in terms of energy efficiency but also in terms of fire protection and functionality.

Retrofitting existing buildings is very often even more complex than designing new ones as the remaining structure has to be included in the design concept and in many cases compromises have to be made to meet standards and requirements.

In this paper a case study is presented relating to the redesign of an office building dating from the 1960s. This example shows the creative potential but also the complexity that lies in the renewal of older buildings. Especially the detailing and the structural complexity of designing the new double skin façade are described.

Built in 1969 the building complex accommodating a bank company sets an important accent within the city centre of Rosenheim, which is a medium size town in Germany. The building consists of a two-storey podium topped by a nine-storey tower, the overall height is 40m above ground level. In order to optimise the building's energy efficiency and present the public a modern appearance the whole building is completely renovated. The existing building envelope which mainly consisted of prefabricated concrete elements was dismantled (Figure 1a, b) and is now replaced by a transparent floor to floor double skin façade. Within the renovation two new storeys (12th and 13th floor)

## Challenging Glass 2

are added. The overall office area is 4000m<sup>2</sup>. The energy consumption will be reduced from 400 kWh/m<sup>2</sup> to 100 kWh/m<sup>2</sup> which is a reduction of 75%.



Figure 1a, b: Dismantling of the Concrete Façade Elements.

The design of the office building dating from the 1960s as well as the redesign was planned by Schleburg Architects, Rosenheim. The floor plan of the nine-storey tower has a rectangular shape having a size of approximately 22.5m x 13m. The outer façade is suspended from steel fins which are mounted on the concrete floors. The dominating glazing parts of the secondary façade have a size of 2.5m x 2.5m, in the 11th floor the glazing height increases to 4.3m. The inner part of the facade consists of an insulated wooden cladding with linear supported floor to floor double glazed systems. Whereas the outer screen consists of glass panels which are locally supported by clamps along their edges.

## 2. Design of the Double Skin Façade

### 2.1. Glazing

The dominating glazing parts of the secondary façade have a size of 2.5m x 2.5m, in the 11th floor the glazing height increases to 4.3m. The glass panels are supported by clamps along their edges. The glass set-up consists of 2 x 10mm laminated heat strengthened glass and in the corner areas of 2 x 12mm laminated heat strengthened glass.

The glass panels are visually broken up by openable louvres which are 0.55m high and 1.25m wide, they are linearly supported along their short edges and have a glass set-up of 2 x 8mm laminated annealed glass. The louvers are used for natural ventilation and will also open in case of any smoke emission. Figure 2 shows the elevation of the façade.

The wind loads were determined based on a wind study which was carried out for the double skin façade.

As the gap between outer and inner façade is to be accessible for cleaning and maintenance the outer façade has to resist also impact loads. Therefore besides the structural analysis impact tests had to be carried out (see section 3).

For the louvers also additional requirements regarding remaining load carrying capacity after glass breakage had to be taken into consideration. This was necessary as the open louvers having an inclination more than  $10^\circ$  are classified as an overhead glazing. The testing is described in section 3. For the secondary glazing of the façade a special permit from the authorities was needed.

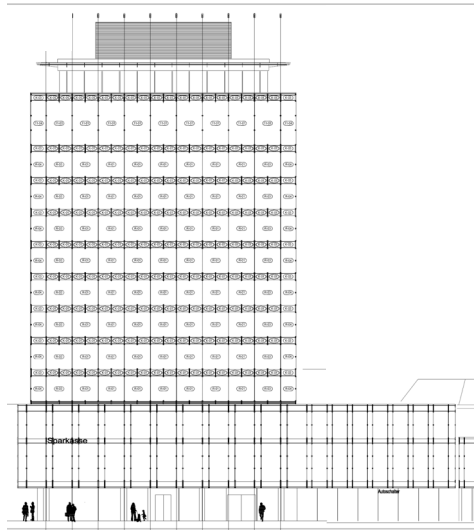

Figure 2: Elevation of the Façade.

## 2.2. Supporting Structure and Detailing

The outer façade is suspended from steel fins which are fixed to the concrete slabs by anchors (Figure 3). The steel fin itself consists of welded flat steel plates (Figure 4).

When designing the supporting elements the main problem was the connection to the concrete structure. Due to the poor concrete quality dating from the 1960s and insufficient reinforcement at the slab edges it was necessary to fix the anchors at defined locations which were able to resist these additional loads (Figure 5). The gap between anchor and drill hole was filled with a suitable mortar to avoid any slip.

Challenging Glass 2

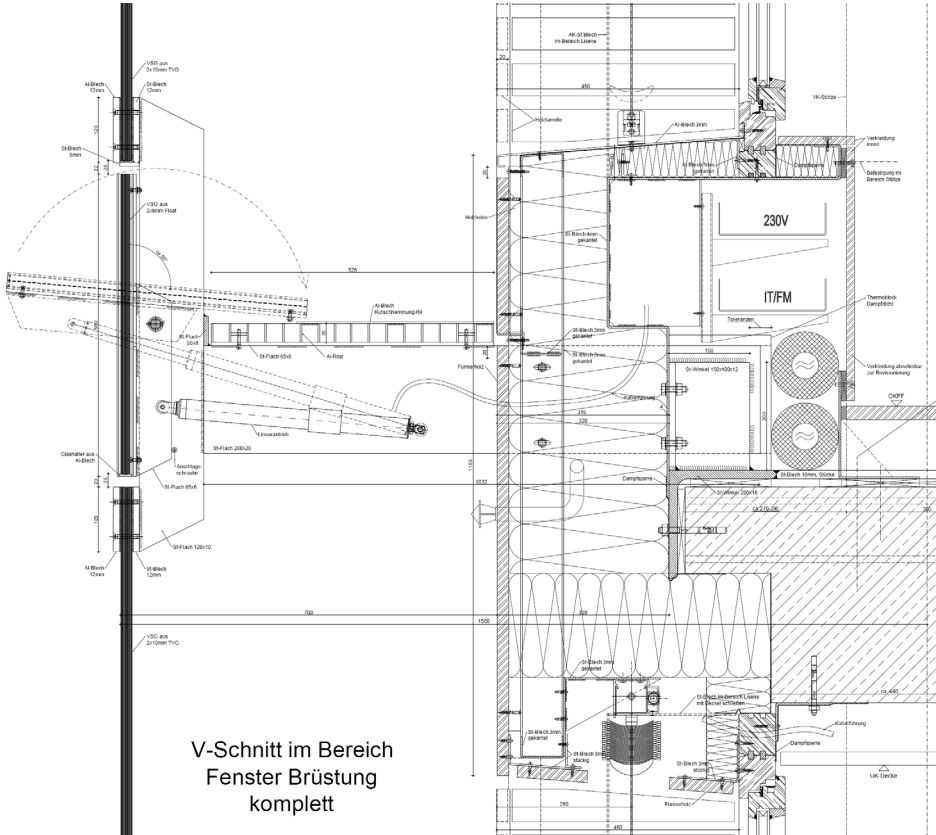

Figure 3: Vertical Section Steel Fin.



Figure 4: Installed Steel Fin.



Figure 5: Steel Fins are fixed to the Concrete Floor by Anchors.

Furthermore complex supporting details had to be developed to transfer the compressive forces locally into a defined area of the concrete edge (Figure 6a). To guarantee a uniform load distribution additionally the gaps between the steel sections and the concrete were filled with a high strength grout (Figure 6b).

The supporting elements were modeled by means of finite element analysis (Figure 7, Figure 8).

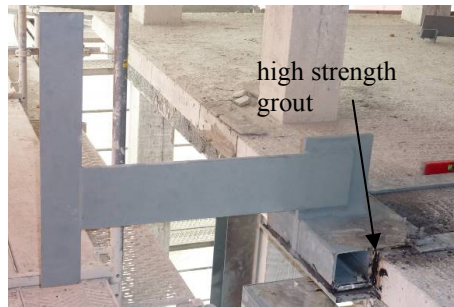
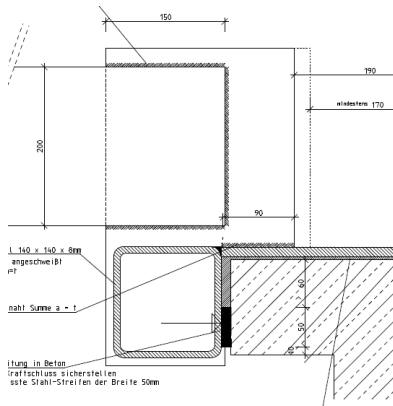

Figure 6a, b: Load Application into the Slab Edge.

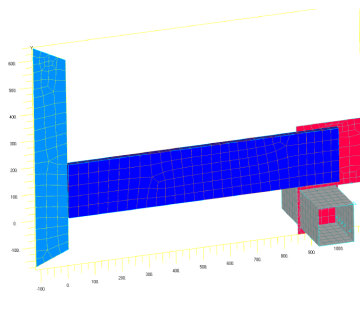

Figure 7: FEA model.

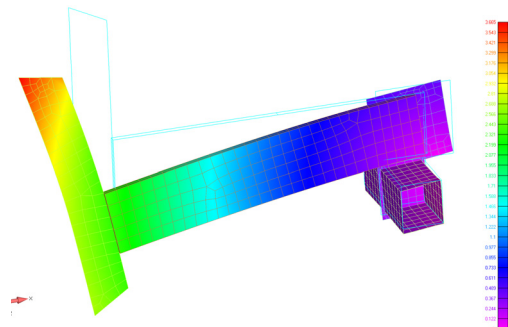

Figure 8: Max. deformation.

### 3. Testing

#### 3.1. Introduction

The design of this complex façade structure should not only be based on numerical simulation therefore full scale tests of the supporting elements were carried out to be able to evaluate the FEA-model in a qualified way (section 3.2).

As the gap between outer and inner façade is to be accessible for cleaning and maintenance the outer façade functions as a barrier and has to resist also impact loads. Therefore for the glazing of the outer skin impact tests were required according to TRAV [7] (section 3.3).

Finally the post-breakage performance of the openable louvres was determined (section 3.4). This was necessary as the open louvers having an inclination more than  $10^\circ$  are classified as an overhead glazing and a safe post-failure behaviour in the event of breakage for people beneath has to be guaranteed.

### 3.2. Deformation of the Outer Skin

Goal of these tests was to verify that there are no significant deformations or any slip of the façade supporting elements induced by dead, wind and traffic loads. The tests were carried out in full scale on site.

The loads were applied step by step starting with the characteristic values. Finally the design values were applied. For each load step the horizontal and vertical deformation was determined (Figure 9).

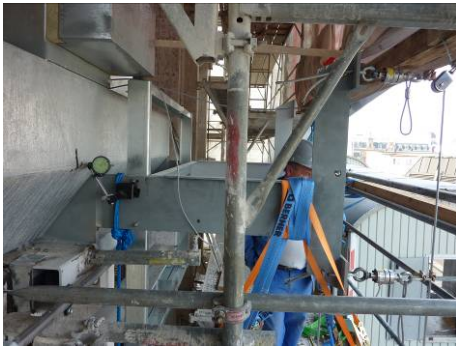

Figure 9 Test set-up.



Figure 10: Load application.

The loads were simulated by cement bags (Figure 10) and fixed to the location of load application by steel cables and deflection pulleys. The exact load value was determined by force transducers.

The following maximum deformations were determined: horizontal direction 1.3mm and vertical direction 5.0mm. These values matched very well with the calculated values of the structural analysis. In the tests no slip of the supporting structure was determined.

### 3.3. Impact Resistance

For the glazing of the secondary façade impact tests according to German TRAV [7] were performed using a standard pendulum according to EN 12600. A drop height of 900mm was used. The tests were carried out in full scale in the laboratory (Figure 11). The impact body hit the specimen on points that caused maximum glass and support damage. After an impact at the corner of the specimen the laminated glass broke (Figure 12), but as the impact body did not penetrate the laminated glass and no dangerous glass fragments fell down the test was passed.



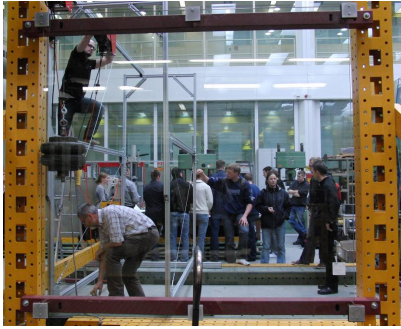

Figure 11: Test set-up.

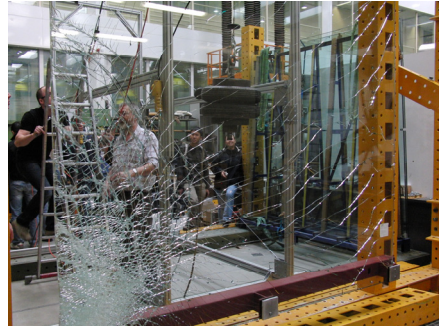

Figure 12: Damaged glass specimen.

### 3.4. Post-breakage performance

To determine the post-breakage performance of the louvres (Figure 3) the laminated glass specimen were placed horizontally and loaded by half of the service load (Figure 13). With the load still applied all the sheets of the laminated glass panel were fractured at several locations by means of a hole punch and a hammer. The tests were carried out successfully: Within 24 hours the specimen did not slide from the supports and no dangerous glass fragments fell down (Figure 14).

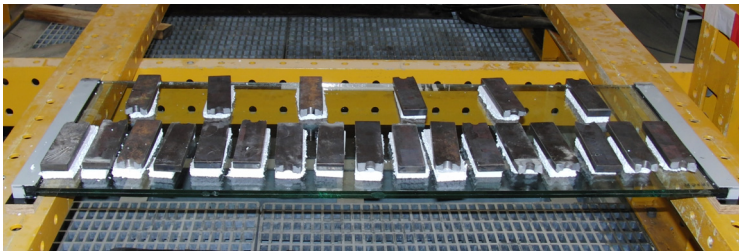

Figure 13 Test set-up with loading

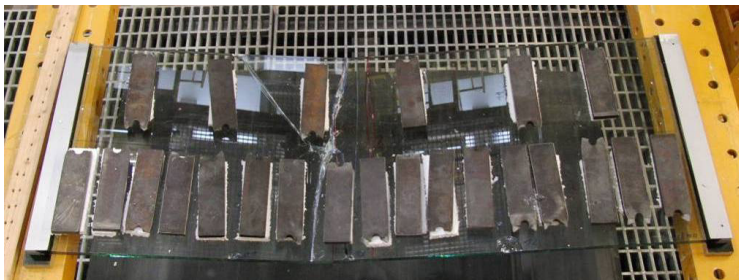

Figure 14: Specimen after testing.

## 4. Conclusion

Retrofitting existing buildings is very often even more complex than designing new ones as the remaining structure has to be included in the design concept and in many cases compromises have to be made to meet standards and requirements.

## Challenging Glass 2

Redesigning this office building the main problem was the connection of the façade supporting elements to the existing concrete structure. Due to the poor concrete quality dating from the 1960s and insufficient reinforcement at the slab edges it was necessary to design special joints and fix the anchors at defined locations which were able to resist these additional loads.

Moreover for the outer glass skin besides the structural analysis additional requirements such as resistance against human impact and post-breakage performance were demanded from the building authorities.

Although redesigning the building was very complex, by improving the energy efficiency and present the public a modern appearance the renovation of the building was very successfully (Figure 15a, b).



Figure 15a, b: New double skin facade

## 5. References

- [1] DIN 18800-1: 1990-11 *Steel structures: design and construction.*
- [2] DIN 1055-3: 2006-03 *Action on structures: self-weight and imposed load in building.*
- [3] DIN 1055-4: 2005-03 *Action on structures: wind loads.*
- [4] DIN 1055-5: 2005-07 *Action on structures : snow loads and ice loads.*
- [5] *Technische Regeln für die Verwendung von linienförmig gelagerten Verglasungen (TRLV)*, final version August 2006.
- [6] *Technische Regeln für die Bemessung und die Ausführung punktförmig gelagerter Verglasungen (TRPV)*, final version August 2006.
- [7] *Technische Regeln für die Verwendung von absturzsichernden Verglasungen (TRAV)*, version January 2003.